

Product information

MQM Quantometer

The MQM Quantometer is a turbine gas meter for operational natural gas volume measurement and for other non-aggressive gases such as propane, butane, air, CO₂ or inert gases used in internal accounting and controlling processes of various types, especially in industrial thermal processing facilities.

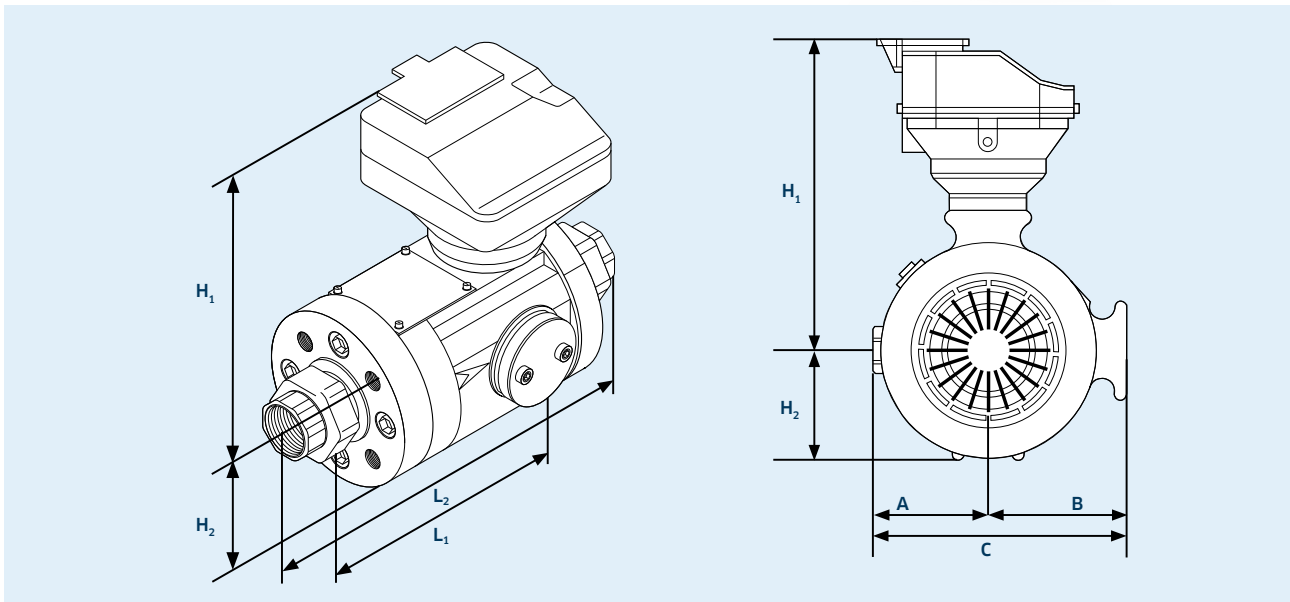

Dimensions, weights, connections

Rp / DN	Housing dimensions (mm)								Weight (kg)
	L ₁	L ₂	A	B	C	H ₁	H ₂		
1" threaded	185	240	64	64	128	152	55	5,0	
1 ½" threaded	210	280	64	64	128	152	55	6,4	
25	150	-	64	64	128	152	55	4,0	
50	60	-	60	72	132	178	52	2,8	
80	120	-	75	97	172	201	71	5,0	
100	150	-	80	107	103	213	80	6,8	
150	180	-	122	123	245	242	105	11,6	

Key features:

- › Meter sizes from G 10 to G 1000
- › Flow rates from 1,6 to 1600 m³/h
- › Nominal sizes from Rp 1" 25 to DN 150
- › Pressure class PN 4/16
- › Measuring ranges up to 1:20
- › Maintenance free based on permanent lubrication of the ball bearings
- › Meter body made of anodized high-strength aluminium
- › Meter index head made of plastic as standard, aluminium as an option
- › Optional: Manual lubrication of the ball bearings via the oil pump
- › Rotating index head (355°)
- › Recommended straight inlet pipe ≥ 3DN and outlet pipe ≥ 2DN
- › Horizontal and vertical mounting position
- › Approval according to DGRL/PED 2014/68/EU (Pressure Equipment Directive)
- › Low-frequency pulse output as standard: HF pulse generator as an option

Technical specifications

The MQM Quantometer is a turbine gas meter that registers the operating volume using an eight-digit mechanical counter. Information on the operating volume is sent to an electronic volume corrector via a pulse generator and it is converted to normal or standard conditions. The MQM Quantometer is a volume flow meter.

The flow of the gas to be measured causes the turbine rotor to rotate. The gas flow is narrowed on an annular cross section, is accelerated and directed onto the smooth-running aluminium rotor. The number of rotations is proportional to the measured gas volume; the frequency of rotations is proportional to the actual gas flow. The rotation of the rotor is connected to a speed-reducing gear train and transmitted via a magnetic

coupling from the gas-pressurized area to the adjustable roller counter in the atmospheric environment.

Connections

Rp		
1" threaded	ISO 7/1	
1 1/2" threaded	ISO 7/1	
DN		
25		
50	4xM16	DIN EN 1092-1PN 16
80	8xM16	DIN EN 1092-1PN 16
100	8xM16	DIN EN 1092-1PN 16
150	8xM20	DIN EN 1092-1PN 16

Type	G-Type	DN / Rp	Type of connection	Measuring range Operating volume flow Qb [m³/h]		Measuring range Ratio	pe max. Gas	HF [imp/m³] * external pulse gen.	NF [imp/m³] internal pulse gen.	Pressure loss (mbar) at Qmax and p=1 bar abs.
				Q min.	Q max.					
MQM	10	Rp 1"	Rp Internal thread	1,6	16	1:10	4 bar	185.000 - 195.000	10	5
MQM	16	Rp 1"	Rp Internal thread	2,5	25	1:10	4 bar	185.000 - 195.000	10	5
MQM	25	Rp 1"	Rp Internal thread	4	40	1:10	4 bar	185.000 - 195.000	10	5
MQM	40	Rp 1"	Rp Internal thread	6,5	65	1:10	4 bar	185.000 - 195.000	10	5
MQM	40	Rp 1 1/2"	Rp Internal thread	6,5	65	1:10	4 bar	185.000 - 195.000	10	5
MQM	10	DN25	Flange	1,6	16	1:10	16 bar	185.000 - 195.000	10	5
MQM	16	DN25	Flange	2,5	25	1:10	16 bar	185.000 - 195.000	10	5
MQM	25	DN25	Flange	4	40	1:10	16 bar	185.000 - 195.000	10	5
MQM	40	DN25	Flange	6,5	65	1:10	16 bar	185.000 - 195.000	10	5
MQM	40	DN50	Flange	3,25	65	1:20	16 bar	101.000 - 107.000	10	3
MQM	65	DN50	Flange	5	100	1:20	16 bar	101.000 - 107.000	10	4
MQM	100	DN80	Flange	8	160	1:20	16 bar	26.400 - 27.200	1	2
MQM	160	DN80	Flange	12,5	250	1:20	16 bar	26.400 - 27.200	1	2
MQM	250	DN80	Flange	20	400	1:20	16 bar	26.400 - 27.200	1	4
MQM	160	DN100	Flange	12,5	250	1:20	16 bar	13.100 - 13.900	1	3
MQM	250	DN100	Flange	20	400	1:20	16 bar	13.100 - 13.900	1	3
MQM	400	DN100	Flange	32	650	1:20	16 bar	13.100 - 13.900	1	6
MQM	400	DN150	Flange	32	650	1:20	16 bar	5.100 - 5.400	1	10
MQM	650	DN150	Flange	50	1000	1:20	16 bar	5.100 - 5.400	1	10
MQM	1000	DN150	Flange	80	1600	1:20	16 bar	5.100 - 5.400	1	10

* =The absolute number of the HF pulses depends on the meter size and the individual meter. The stated values are typical sizes. Exact values are determined during calibration of the meter and are stated on the nameplate.



MQM Quantometer
(Rp 1" internal thread)



Oil pump for lubricating ball bearings
(optional)



Metreg Technologies GmbH

Metreg Technologies GmbH

Tränkeweg 9
15517 Fürstenwalde
Telefon: +49 (0)3361 760 20-80
info@metreg-technologies.de
www.metreg-technologies.de